

Low Noise Ceramic Packaged PHEMT GaAs FETs

FEATURES

- 0.5 dB Typical Noise Figure at 12 GHz
- High Associated Gain:
Ga = 13 dB Typical at 12 GHz
- Lg = 0.25 μm, Wg = 160 μm
- 100 % DC Tested
- Micro-X Metal Ceramic Package

PHOTO ENLARGEMENT



DESCRIPTION

The TC2182 is a high performance field effect transistor housed in a ceramic micro-x package with TC1102 PHEMT Chip. It has very low noise figure, high associated gain and high dynamic range that makes this device suitable for use in low noise amplifiers. All devices are 100 % DC tested to assure consistent quality.

ELECTRICAL SPECIFICATIONS (T_A=25 °C)

Symbol	CONDITIONS	MIN	TYP	MAX	UNIT
NF	Noise Figure at V _{DS} = 2 V, I _{DS} = 10 mA, f = 12GHz		0.5	0.7	dB
G _a	Associated Gain at V _{DS} = 2 V, I _{DS} = 10 mA, f = 12GHz	10	13		dB
I _{DSS}	Saturated Drain-Source Current at V _{DS} = 2 V, V _{GS} = 0 V		40		mA
g _m	Transconductance at V _{DS} = 2 V, V _{GS} = 0 V		55		mS
V _P	Pinch-off Voltage at V _{DS} = 2 V, I _D = 0.32mA		-1.0*		Volts
BV _{DGO}	Drain-Gate Breakdown Voltage at I _{DGO} = 0.08mA	5	9		Volts
R _{th}	Thermal Resistance		130		°C/W

ABSOLUTE MAXIMUM RATINGS (T_A=25 °C)

Symbol	Parameter	Rating
V _{DS}	Drain-Source Voltage	5.0 V
V _{GS}	Gate-Source Voltage	-3.0 V
I _{DS}	Drain Current	I _{DSS}
I _{GS}	Gate Current	160 μA
P _{in}	RF Input Power, CW	14 dBm
P _T	Continuous Dissipation	150 mW
T _{CH}	Channel Temperature	175 °C
T _{STG}	Storage Temperature	- 65 °C to +175 °C

TYPICAL NOISE PARAMETERS (T_A=25 °C)

V_{DS} = 2 V, I_{DS} = 10 mA

Frequency	NF _{opt}	G _A	Γ _{opt}		Rn/50
			MAG	ANG	
2	0.32	19.0	0.98	15	0.40
4	0.33	17.4	0.84	30	0.35
6	0.35	15.7	0.68	50	0.26
8	0.39	14.3	0.51	76	0.19
10	0.44	12.9	0.38	107	0.12
12	0.50	11.9	0.28	146	0.08
14	0.58	11.4	0.25	-167	0.07
16	0.74	11.2	0.32	-110	0.11
18	0.91	10.9	0.49	-43	0.23

* For the tight control of the pinch-off voltage range, we divide TC2182 into 3 model numbers to fit customer design requirement (1)TC2182P0710 : V_p = -0.7V to -1.0V (2)TC2182P0811 : V_p = -0.8V to -1.1V (3)TC2182P0912 : V_p = -0.9V to -1.2V
 If required, customer can specify the requirement in purchasing document. For special V_p requirement, please contact factory for details.

TYPICAL SCATTERING PARAMETERS (T_A=25 °C)

V_{DS} = 2 V, I_{DS} = 10 mA

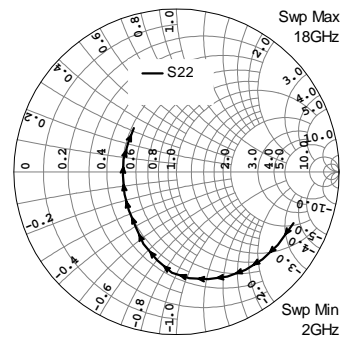
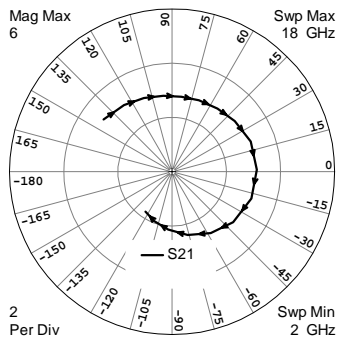
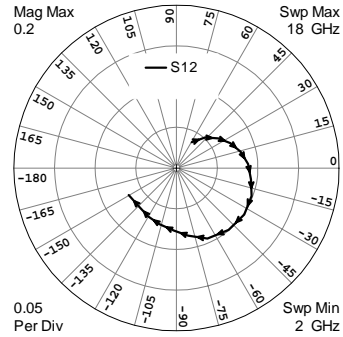
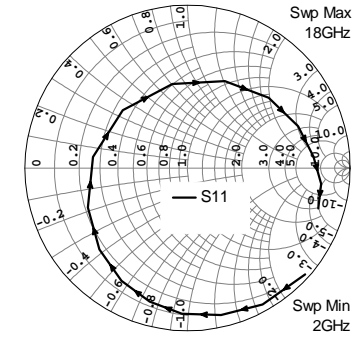

FREQUENCY (GHz)	S11		S21		S12		S22	
	MAG	ANG	MAG	ANG	MAG	ANG	MAG	ANG
2	0.9753	-42.07	3.1849	142.77	0.0369	59.34	0.7846	-23.66
3	0.9569	-61.12	3.0294	125.98	0.0513	46.68	0.7686	-35.81
4	0.9265	-77.16	2.9072	110.95	0.0630	35.35	0.7527	-45.49
5	0.8962	-92.19	2.8197	96.54	0.0730	24.64	0.7363	-54.79
6	0.8537	-105.88	2.7887	83.04	0.0814	14.13	0.7155	-64.11
7	0.8033	-120.43	2.8169	69.49	0.0881	3.31	0.6888	-73.57
8	0.7371	-137.29	2.8673	54.47	0.0928	-8.79	0.6577	-83.22
9	0.6585	-158.26	2.9755	38.95	0.0983	-20.39	0.6205	-92.67
10	0.5848	173.39	3.1034	21.12	0.1008	-34.42	0.5566	-102.37
11	0.5334	138.30	3.1303	1.49	0.0994	-49.95	0.4882	-114.51
12	0.5244	100.31	3.0858	-18.68	0.0944	-66.31	0.4195	-127.04
13	0.5796	66.75	2.9214	-39.53	0.0845	-80.16	0.3765	-141.50
14	0.6593	40.81	2.6705	-57.67	0.0772	-92.37	0.3475	-156.59
15	0.7259	20.68	2.4002	-76.28	0.0721	-106.83	0.3306	-175.60
16	0.7778	5.14	2.1397	-93.90	0.0687	-120.22	0.3351	166.49
17	0.8265	-6.70	1.9291	-109.65	0.0660	-133.41	0.3471	149.44
18	0.8424	-17.16	1.7749	-123.77	0.0674	-150.56	0.3744	134.41

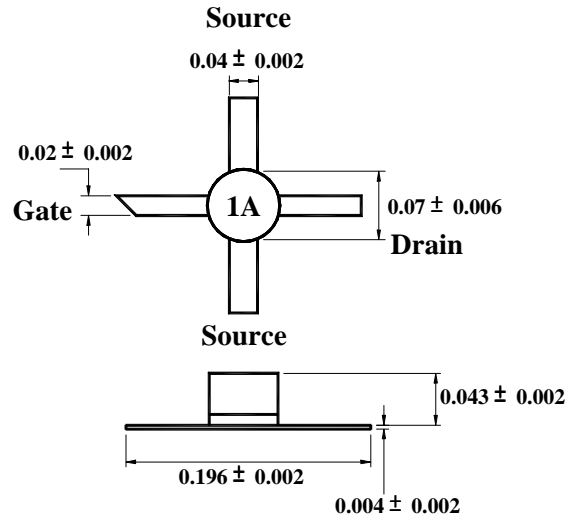
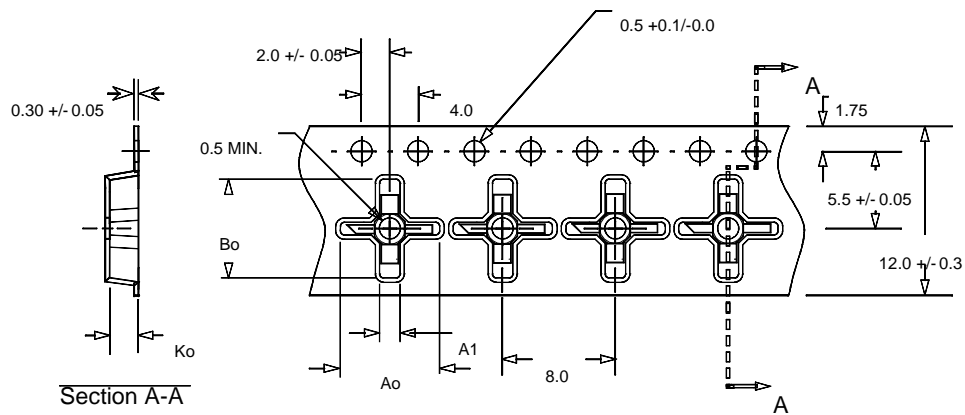
OUTLINE DIMENSIONS (in mm)

Tape & Reel Package Orientation (mm)

$A_o = 7.0 \text{ mm}$
 $A_1 = 1.45 \text{ mm}$
 $B_o = 7.0 \text{ mm}$
 $B_1 = 0.9 \text{ mm}$
 $K_o = 2.0 \text{ mm}$

Standard Reel Size	7"
Standard Reel Quantity	1000