

1 W Flange Ceramic Packaged PHEMT GaAs Power FETs

FEATURES

- 1 W Typical Output Power at 6 GHz
- 12 dB Typical Linear Power Gain at 6 GHz
- High Linearity:
IP3 = 40 dBm Typical at 6 GHz
- High Power Added Efficiency:
Nominal PAE of 43 % at 6 GHz
- Suitable for High Reliability Application
- Breakdown Voltage:
 $BV_{DGO} \geq 15 \text{ V}$
- $L_g = 0.35 \mu\text{m}$, $W_g = 2.4 \text{ mm}$
- 100 % DC Tested
- Flange Ceramic Package

PHOTO ENLARGEMENT



DESCRIPTION

The TC2591 is packaged with the TC1501 Pseudomorphic High Electron Mobility Transistor (PHEMT) chip. The flange ceramic package provides the best thermal conductivity for the GaAs FET. All devices are 100% DC and RF tested to assure consistent quality. Typical applications include high dynamic range power amplifier for commercial applications including Cellular/PCS systems, and military high performance power amplifier.

ELECTRICAL SPECIFICATIONS ($T_A = 25^\circ\text{C}$)

Symbol	CONDITIONS	MIN	TYP	MAX	UNIT
P_{1dB}	Output Power at 1dB Gain Compression Point, $f = 6\text{GHz}$ $V_{DS} = 8 \text{ V}$, $I_{DS} = 300 \text{ mA}$	29.5	30		dBm
G_L	Linear Power Gain, $f = 6\text{GHz}$ $V_{DS} = 8 \text{ V}$, $I_{DS} = 300 \text{ mA}$	11	12		dB
IP3	Intercept Point of the 3 rd -order Intermodulation, $f = 6\text{GHz}$ $V_{DS} = 8 \text{ V}$, $I_{DS} = 300 \text{ mA}$, $*P_{SCL} = 17 \text{ dBm}$		40		dBm
PAE	Power Added Efficiency at 1dB Compression Power, $f = 6\text{GHz}$		43		%
I_{DSS}	Saturated Drain-Source Current at $V_{DS} = 2 \text{ V}$, $V_{GS} = 0 \text{ V}$		600		mA
g_m	Transconductance at $V_{DS} = 2 \text{ V}$, $V_{GS} = 0 \text{ V}$		400		mS
V_p	Pinch-off Voltage at $V_{DS} = 2 \text{ V}$, $I_D = 4.8 \text{ mA}$		-1.7**		Volts
BV_{DGO}	Drain-Gate Breakdown Voltage at $I_{DGO} = 1.2 \text{ mA}$	15	18		Volts
R_{th}	Thermal Resistance		14		$^\circ\text{C/W}$

Note: * P_{SCL} : Output Power of Single Carrier Level.

** For the tight control of the pinch-off voltage range, we divide TC2591 into 3 model numbers to fit customer design requirement (1)TC2591P1519 : $V_p = -1.5\text{V}$ to -1.9V (2)TC2591P1620 : $V_p = -1.6\text{V}$ to -2.0V (3)TC2591P1721 : $V_p = -1.7\text{V}$ to -2.1V
If required, customer can specify the requirement in purchasing document. For special V_p requirement, please contact factory for details.

ABSOLUTE MAXIMUM RATINGS (T_A=25 °C)

Symbol	Parameter	Rating
V _{DS}	Drain-Source Voltage	12 V
V _{GS}	Gate-Source Voltage	-5 V
I _{DS}	Drain Current	I _{DSS}
P _{in}	RF Input Power, CW	26 dBm
P _T	Continuous Dissipation	3.8 W
T _{CH}	Channel Temperature	175 °C
T _{STG}	Storage Temperature	- 65 °C to +175 °C

RECOMMENDED OPERATING CONDITION

Symbol	Parameter	Rating
V _{DS}	Drain to Source Voltage	8 V
I _D	Drain Current	300 mA

HANDLING PRECAUTIONS:

The user must operate in a clean, dry environment. Electrostatic Discharge (ESD) precautions should be observed at all stages of storage, handling, assembly, and testing. The static discharge must be less than 300V.

TYPICAL SCATTERING PARAMETERS (T_A=25 °C)

V_{DS} = 8 V, I_{DS} = 300 mA

FREQUENCY (GHz)	S11		S21		S12		S22	
	MAG	ANG	MAG	ANG	MAG	ANG	MAG	ANG
2	0.9111	-167.09	3.8048	68.95	0.0337	-10.27	0.4441	170.74
3	0.8964	166.15	2.8222	42.16	0.0378	-31.72	0.4297	157.73
4	0.8794	141.85	2.3866	16.06	0.0429	-52.55	0.3963	143.48
5	0.8578	114.38	2.1913	-12.25	0.0497	-75.68	0.3453	124.99
6	0.8360	79.47	2.0878	-44.97	0.0575	-103.32	0.2799	96.28
7	0.8306	34.88	1.9288	-83.30	0.0627	-136.68	0.2361	45.65
8	0.8581	-14.11	1.5922	-125.20	0.0600	-173.75	0.3061	-16.20
9	0.9001	-56.65	1.1456	-165.31	0.0493	150.84	0.4635	-58.84

OUTLINE DIMENSIONS (in mm)

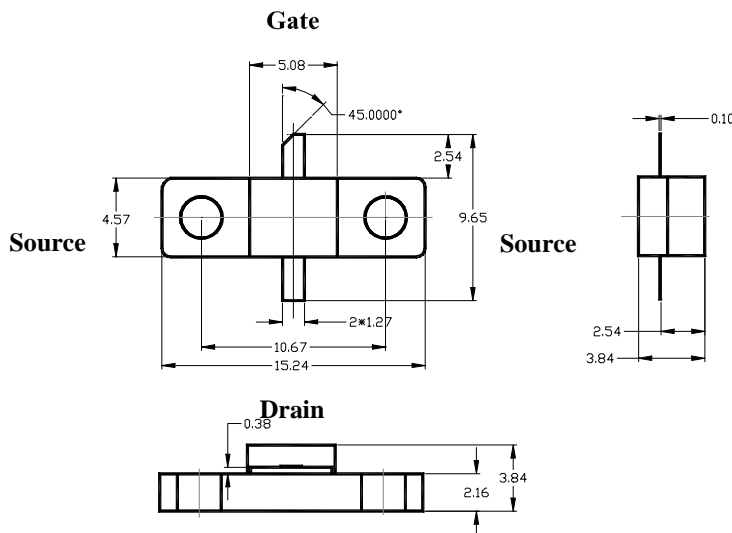

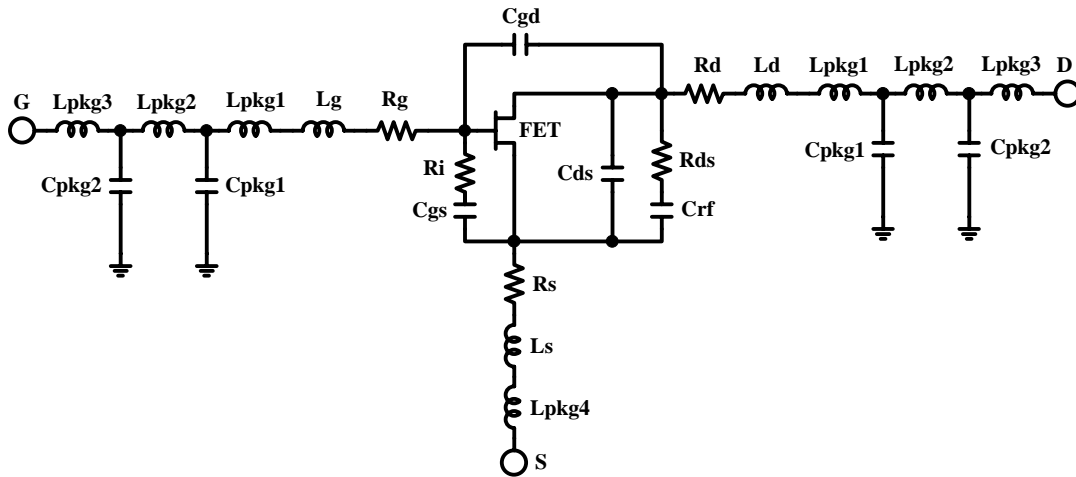
NONLINEAR MODEL

TOM2 MODEL PARAMETERS

Parameters		Parameters	
VTO	-2 V	CGD	0.22 pF
ALPHA	4.54	CGS	4.04 pF
BETA	0.399	CDS	0.62 pF
GAMMA	0.0084	VBR	15 V
DELTA	0.003	TNOM	27 °C
Q	1.055	LS	0.009 nH
NG	0	LG	0.0475 nH
ND	0.01	LD	0.032 nH
TAU	3.9 ps	Rds	10.29 Ohm
RG	0.65 Ohm	Ri	0.0375 Ohm
RD	0.675 Ohm	Crf	1E-7 PF
RS	0.475 Ohm	Lpkg1	0.1 nH
IS	1E-14 mA	Lpkg2	0.16 nH
N	1	Lpkg3	0.07 nH
VBI	0.68 V	Lpkg4	0.032 nH
VDELTA	0.2 V	Cpkg1	0.42 PF
VMAX	0.5 V	Cpkg2	0.26 PF

MODEL RANGE

Frequency: 0.5 to 10 GHz

 Bias: $V_{DS} = 1V$ to $8V$, $I_D = 100mA$ to $600mA$
 $I_{DS} = 600mA$ at $V_{GS} = 0V$, $V_{DS} = 2V$