

Preliminary 1.9GHz 12 W Flange Ceramic Packaged GaAs Power FETs
FEATURES

- 12 W Typical Power at 1.9 GHz
- 13 dB Typical Linear Power Gain at 1.9 GHz
- High Linearity:
IP3 = 50 dBm Typical
- High Power Added Efficiency:
Nominal PAE of 40 %
- Suitable for High Reliability Application
- $L_g = 1 \mu\text{m}$, $W_g = 30 \text{ mm}$
- 100 % DC and RF Tested
- Flange Ceramic Package

PHOTO ENLARGEMENT

DESCRIPTION

The TC2996B is a packaged Pseudomorphic High Electron Mobility Transistor (PHEMT) power transistor. The flange ceramic package provides the best thermal conductivity for the GaAs FET. All devices are 100% DC and RF tested to assure consistent quality. Typical applications include high dynamic range power amplifier for commercial applications.

ELECTRICAL SPECIFICATIONS (@ 1.9 GHz)

SYMBOL	CONDITIONS	MIN	TYP	MAX	UNIT
P_{1dB}	Output Power at 1dB Gain Compression Point $V_{DS} = 10 \text{ V}$, $I_{DS} = 2.5 \text{ A}$	39.5	41.0		dBm
G_L	Linear Power Gain $V_{DS} = 10 \text{ V}$, $I_{DS} = 2.5 \text{ A}$	12	13		dB
IP3	Intercept Point of the 3 rd -order Intermodulation, $V_{DS} = 10 \text{ V}$, $I_{DS} = 2.5 \text{ A}$, * $P_{SCL} = 28 \text{ dBm}$		50		dBm
PAE	Power Added Efficiency at 1dB Compression Power		40		%
I_{DSS}	Saturated Drain-Source Current at $V_{DS} = 2 \text{ V}$, $V_{GS} = 0 \text{ V}$		7.5		A
g_m	Transconductance at $V_{DS} = 2 \text{ V}$, $V_{GS} = 0 \text{ V}$		5400		mS
V_p	Pinch-off Voltage at $V_{DS} = 2 \text{ V}$, $I_D = 60 \text{ mA}$		-1.7		Volts
BV_{DGO}	Drain-Gate Breakdown Voltage at $I_{DGO} = 15 \text{ mA}$	20	22		Volts
R_{th}	Thermal Resistance		1.5		°C/W

* P_{SCL} : Output Power of Single Carrier Level.

ABSOLUTE MAXIMUM RATINGS at 25 °C

Symbol	Parameter	Rating
V _{DS}	Drain-Source Voltage	12 V
V _{GS}	Gate-Source Voltage	-5 V
I _{DS}	Drain Current	I _{DSS}
P _{in}	RF Input Power, CW	32 dBm
P _T	Continuous Dissipation	60 W
T _{CH}	Channel Temperature	175 °C
T _{STG}	Storage Temperature	- 65 °C to +175 °C

HANDLING PRECAUTIONS:

The user must operate in a clean, dry environment. Electrostatic Discharge (ESD) precautions should be observed at all stages of storage, handling, assembly, and testing. The static discharge must be less than 300V.

FLANGE PACKAGE OUTLINE (in mm)

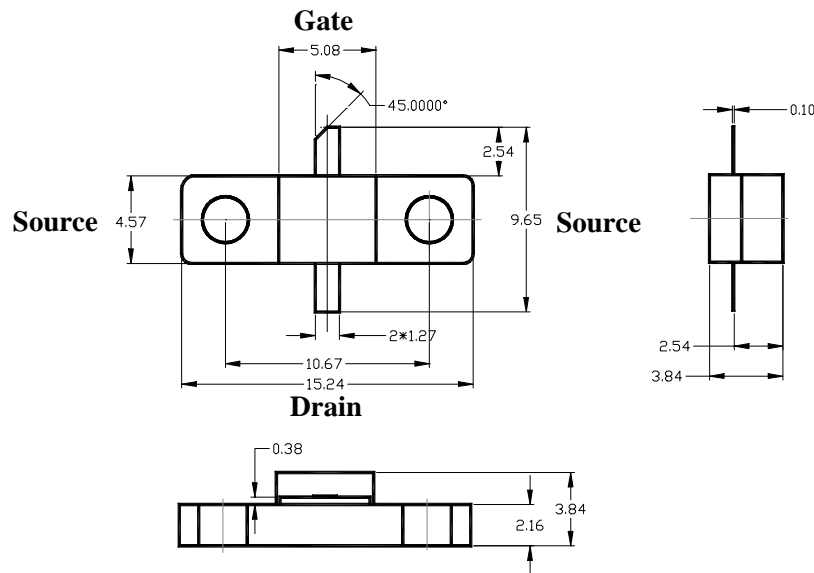

TYPICAL COMMON SOURCE SCATTERING PARAMETERS (V_D = 10 V, I_D = 2.5 A)

FREQUENCY (GHz)	S11		S21		S12		S22	
	MAG	ANG	MAG	ANG	MAG	ANG	MAG	ANG
1	0.98594	174.59	0.99195	49.618	0.006454	-28.741	0.71594	-163.61
2	0.93861	172.82	0.89877	-68.601	0.010435	-127.32	0.98480	-172.81
3	0.99773	165.13	0.09707	-125.68	0.001768	-156.24	0.94714	179.61
4	0.99921	158.57	0.02972	-135.99	0.000940	-144.13	0.96184	175.04
5	0.99931	151.93	0.01351	-141.86	0.000717	-137.94	0.97169	170.70
6	0.99920	144.83	0.00762	-146.81	0.000618	-136.73	0.97762	166.59

EVALUATION BOARD

PCB Material: FR4

ER = 4.6

Thickness = 31 mil

Unit: mil

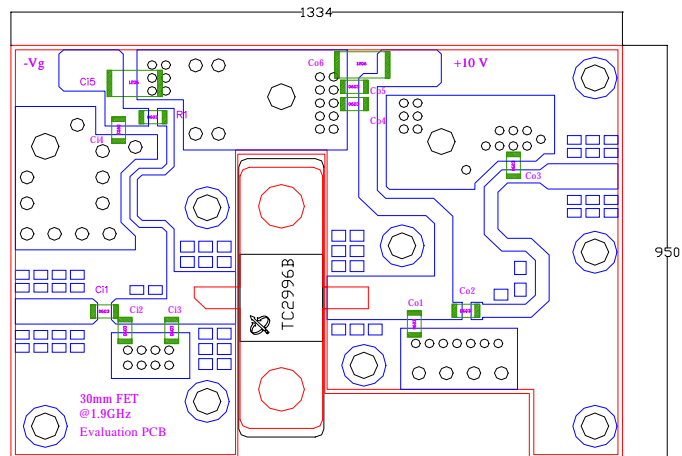

Part Type	Reference Designator	Description	Manufacturer
Resistor	R1	12 ohm 0603	
Capacitor	Ci1	1.0 pF 0603	Murata
Capacitor	Ci2	1.0 pF 0603	Murata
Capacitor	Ci3	1.2 pF 0603	Murata
Capacitor	Ci4	1000 pF 0603	Murata
Capacitor	Ci5	10 uF 1206	Murata
Capacitor	Co1	2.2 pF 0603	Murata
Capacitor	Co2	1.0 pF 0603	Murata
Capacitor	Co3	1.5 pF 0603	Murata
Capacitor	Co4	1000 pF 0603	Murata
Capacitor	Co5	0.1 uF 0603	Murata
Capacitor	Co6	10 uF 1206	Murata