

3.3 - 3.7 GHz 2W MMIC

FEATURES

- P₋₁ dB: 32.5 dBm
- Small Signal Gain: 27 dB
- Power Added Efficiency: 30 %
- IP3: 42 dBm
- Match to 50 Ω operation
- Bias condition: 700 mA @ 8 V

PHOTO ENLARGEMENT



DESCRIPTION

The TC3341 is a 2-stage PHEMT MMIC power amplifier. It is designed for use in low cost, high volume, 3.3-3.7 GHz band applications. The MMIC is matched to 50Ω operation. It provides a typical gain of 27 dB and P1dB power of more than 32.5 dBm. Typical bias condition is 8V at 700 mA. The MMIC is packaged in a copper based ceramic 10 pins power package. The copper based carrier of the package allows direct soldering of the device to the PCB.

APPLICATIONS

- Wireless Internet Access
- Wireless Local Loop
- Two way radio

ELECTRICAL SPECIFICATIONS (Ta = 25 °C)

SYMBOL	DESCRIPTION	MIN	TYP	MAX	UNITS
FREQ	Frequency Range	3.3		3.7	GHz
SSG	Small Signal Gain	26	27		dB
GOF	Small Signal Gain Flatness		±0.5		
P₋₁ dB	Output Power at 1 dB Gain Compression	31.5	32.5		dBm
P₋₃ dB	Output Power at 3 dB Gain Compression	32	33		dBm
IP3	Third Order Intercept Point	40	42		dBm
VSWR, IN	Input VSWR		2:1		
VDD	Supply Voltage		8		Volt
Vg	Gate Voltage	-0.6	-1.0	-1.5	Volt
IDD	Current Supply Without RF		700		mA
IDP₋₁	Current Supply @ Pout=P ₋₁ dB		750		mA
η_a	Power Added Efficiency		30		%

Absolute Maximum Ratings

Symbol	Parameter/Conditions	Min.	Max.	Units
V_{dd}	Drain-Source Voltage		12	Volts
I_{dd}	Total Drain Current		2200	MA
P_{in}	RF Input Power		10	dBm
P_t	Power Dissipation		12	W
T_{ch}	Operating Channel Temperature		175	°C
T_{STG}	Storage Temperature	-65	175	°C

Note:

1. This GaAs MMIC is susceptible to damage from Electrostatic Discharge. Proper precautions should be used when handling these devices.
2. Specifications subject to change without notice.

TEST CIRCUITS

Evaluation Board Schematic

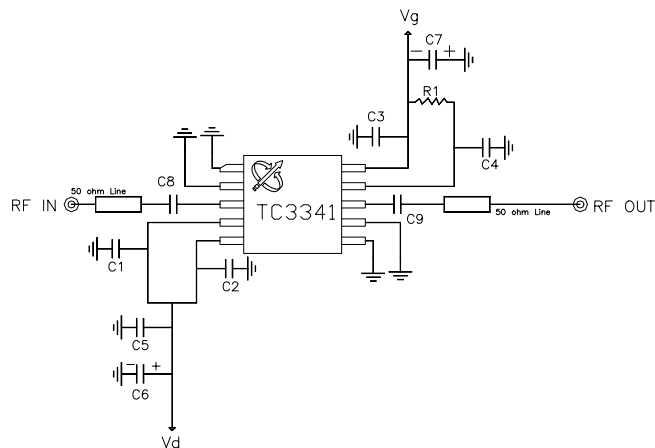

EVALUATION BOARD

DXF file of the PCB can be downloaded from our web-site

at www.transcominc.com.tw

PCB Material: RO4003

ER = 3.38

Thickness = 20 mil

Unit: mil

Application Notes:

For better heat sinking and grounding, it's recommended to have the via holes beneath TC3341 filled with solder and have two screws installed on required heat sink plate besides TC3341 on the PCB area.

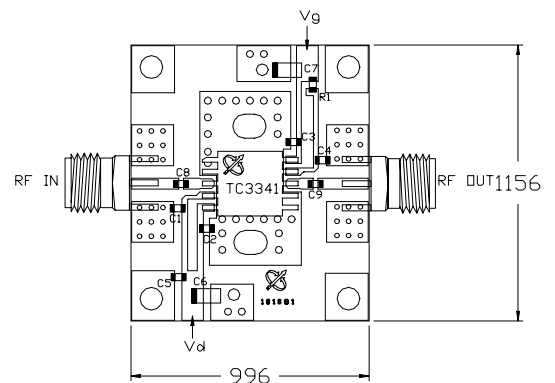

Evaluation Board Parts List

Part Type	Reference Designator	Description	Manufacturer	Part Number
Capacitor	C1, C2, C3, C4	1000pF 0603	Murata	GRM39C0G102J50V
Capacitor	C5	0.1 uF 0603	Murata	GRM39Y5V104Z25V
Capacitor	C6, C7	4.7uF Tantalum Cap.		
Capacitor	C8	2.5pF 0603	Murata	GRM39C0G2R5C50V
Capacitor	C9	3.3pF 0603	Murata	GRM39C0G3R3C50V
Resistor	R1	200 ohm 0603		

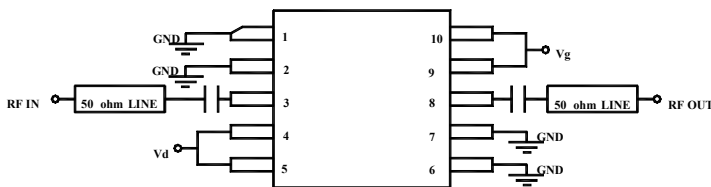

Pin #	Name	Description
1, 2, 6, 7	GND	Ground
3	RF IN	RF input (internally DC blocked)
4, 5	V _d	MMIC drain bias
9, 10	V _g	MMIC gate bias
8	RF OUT	RF output (internally DC blocked)

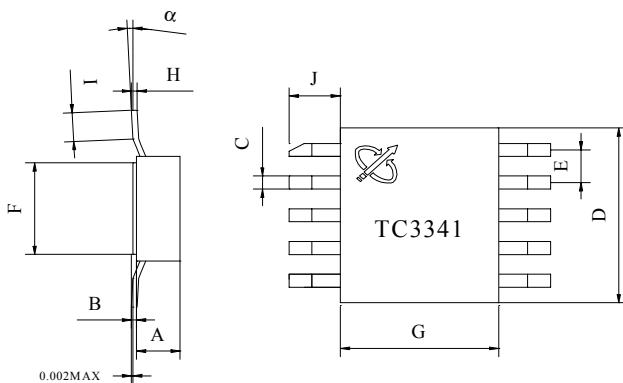
CONNECTION DIAGRAM AND PIN DESCRIPTIONS
PHYSICAL DIMENSIONS (Unit: inches)

DIMENSION	MINIMUM	NOMINAL	MAXIMUM
A	0.054	0.057	0.060
B	0.007	0.008	0.009
C	0.017	0.020	0.023
D	0.267	0.270	0.273
E	0.047	0.050	0.053
F	0.247	0.250	0.253
G	0.267	0.270	0.273
H	0.007	0.008	0.009
I	0.020		0.040
J	0.073	0.080	0.087
α	0°		7°