

## 4.9 - 6 GHz 29dBm Self-Bias MMIC

### FEATURES

- P<sub>-1</sub> dB: 29 dBm
- Small Signal Gain: 21 dB
- Power Added Efficiency: 25 %
- IP3: 39 dBm
- Match to 50 Ω operation
- Bias condition: 400 mA @ 8 V

### PHOTO ENLARGEMENT



### DESCRIPTION

The TC3532 is a 2-stage PHEMT MMIC power amplifier. It requires only a single positive supply. It is designed for use in low cost, high volume, 4.9~6 GHz band applications. The MMIC is matched to 50Ω operation. No external matching component is required. It provides a typical gain of 21 dB and P<sub>1dB</sub> power of more than 29 dBm. Typical bias condition is 8V at 400 mA. The MMIC is packaged in a Ceramic 10 Pins package. The copper based carrier of the package allows direct soldering of the device to the PCB.

### APPLICATIONS

- Wireless Internet Access

### ELECTRICAL SPECIFICATIONS (Ta = 25 °C)

SYMBOL	DESCRIPTION	MIN	TYP	MAX	UNITS
<b>FREQ</b>	Frequency Range	4.9		6	GHz
<b>SSG</b>	Small Signal Gain	19	21		dB
<b>GOF</b>	Small Signal Gain Flatness		±0.5		dB
<b>P<sub>-1</sub> dB</b>	Output Power at 1 dB Gain Compression	28	29		dBm
<b>P<sub>-3</sub> dB</b>	Output Power at 3 dB Gain Compression	29	30		dBm
<b>IP3</b>	Third Order Intercept Point	37	39		dBm
<b>VSWR, IN</b>	Input VSWR		2:1		
<b>VDD</b>	Supply Voltage		8		Volt
<b>IDD</b>	Current Supply Without RF		400		mA
<b>IDP<sub>-1</sub></b>	Current Supply @ P <sub>out</sub> =P <sub>-1</sub> dB		420		mA
<b>η<sub>a</sub></b>	Power Added Efficiency		25		%

**TEST CIRCUITS**

## Evaluation Board Schematic

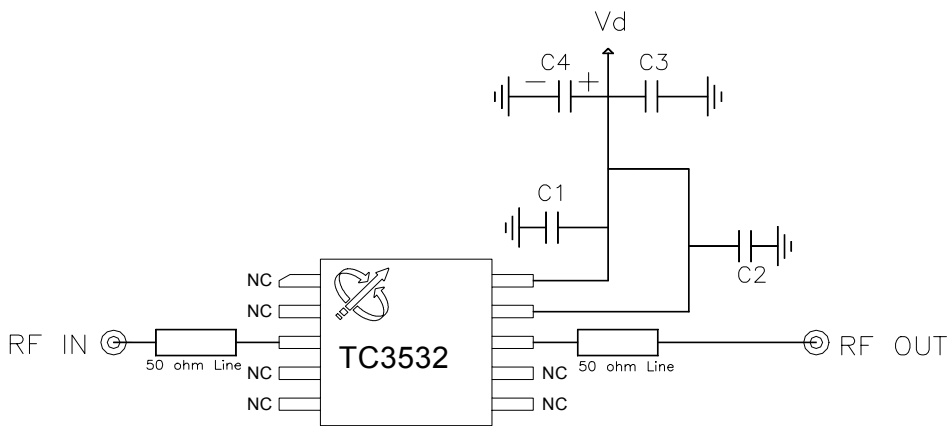
**EVALUATION BOARD**

 DXF file of the PCB can be downloaded from our web-site at [www.transcominc.com.tw](http://www.transcominc.com.tw)

PCB Material: RO4003

ER = 3.38

Thickness = 20 mil

Unit: mil

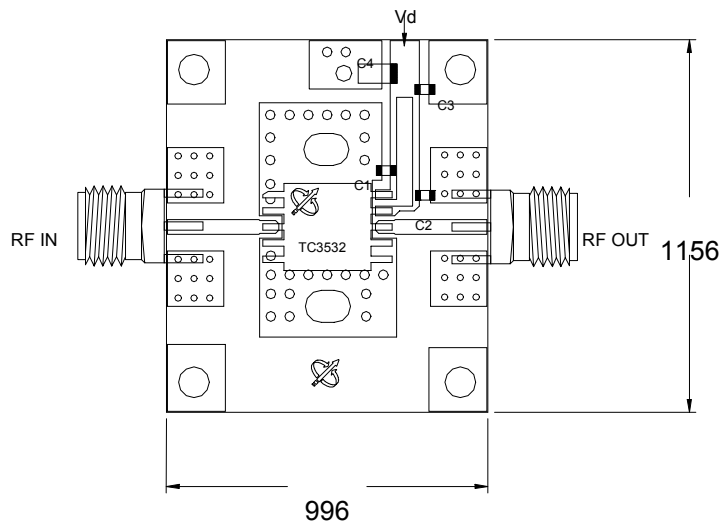

## Application Notes:

For better heat sinking and grounding,  
 it's recommended to have the via holes  
 beneath TC3532 filled with solder and  
 have two screws besides TC3532  
 installed on the PCB area.

**Evaluation Board Parts List**

Part Type	Reference Designator	Description	Manufacturer	Part Number
Capacitor	C1, C2	0.1 uF 0603	Murata	GRM39Y5V104Z25V
Capacitor	C3	1000pF 0603	Murata	GRM39C0G102J50V
Capacitor	C4	4.7uF Tantalum Cap.		

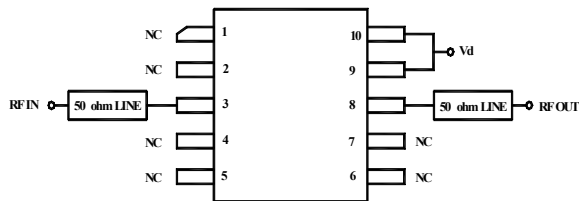
**CONNECTION DIAGRAM AND PIN DESCRIPTIONS**

Pin #	Name	Description
3	RF IN	RF input
9, 10	Vd	MMIC Drain bias
8	RF OUT	RF output (internally DC blocked)
Others	NC	No Connection

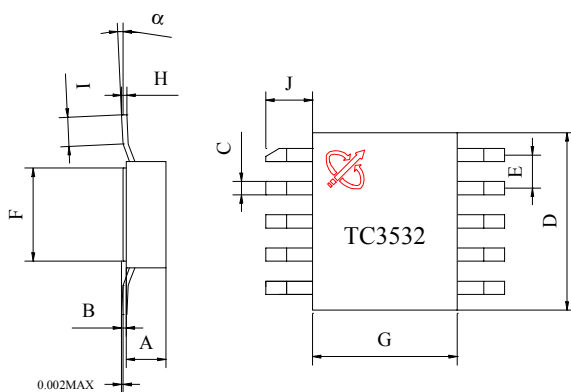
**PHYSICAL DIMENSIONS (Unit: inches)**

DIMENSION	MINIMUM	NOMINAL	MAXIMUM
A	0.054	0.057	0.060
B	0.007	0.008	0.009
C	0.017	0.020	0.023
D	0.267	0.270	0.273
E	0.047	0.050	0.053
F	0.247	0.250	0.253
G	0.267	0.270	0.273
H	0.007	0.008	0.009
I	0.020		0.040
J	0.073	0.080	0.087
α	0°		7°